



ZHEJIANG HANGCHA IMP. & EXP. CO., LTD.

Factory site: 666 Xiangfu Road,  
Hangzhou, Zhejiang, China (311305)

Tel: +86-571-88926735 88926755  
Fax: +86-571-88926789 88132890

sales@hcforklift.com  
www.hcforklift.com



Follow us on  
Facebook



Follow us on  
YouTube



Follow us on  
WeChat



ISO14001  
ISO14001:2015



ISO9001  
ISO9001:2015



HANGCHA trucks conform  
to the European Safety  
Requirements.

2019 VERSION 2/COPYRIGHT 2019/12

HANGCHA GROUP CO., LTD. reserves the right to make any changes without notice concerning colors, equipment, or specifications detailed in this brochure, or to discontinue individual models. The colors of trucks, delivered may differ slightly from those in brochures.



**STAGE V**  
CERTIFIED

## XF Series Diesel / LPG Counterbalanced Trucks

with capacities of 5,000 to 7,000kg

*The World of Hangcha*



# HANGCHA be with you at every stage

Efficient, reliable solutions for your demands

## STAGE V

With Hangcha you can meet all Stage V emissions standards which provides customer demands for value, innovation and performance. The technologies include common rail fuel systems, turbocharged Inter-cooled ,EGR + DOC + DPF. Designed and optimised to every engine model, our forklift truck maximises efficiency and reliability.

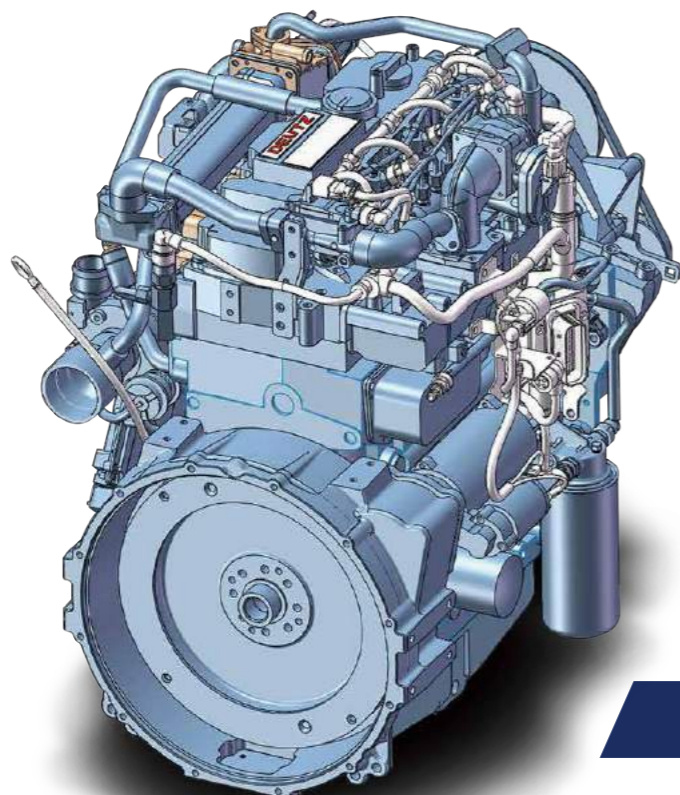

**DEUTZ**



Interactive instrument: The instrument adopts 4.0-inch color LCD display with four interactive buttons, and has one CAN bus communication function. The communication protocol is compatible with CANopen and SAE J1939 standards.

**Powerful/  
Efficient/  
Reliable**



### HANGCHA Forklift with StageV

No.	Capacity	Series	Manufacturer	Engine	Drive power	Model	Emission Std.	Transmission	Power (kw/rpm)	Service brake
1	5.0-7.0t	XF	DEUTZ	TCD 3.6 L4 EU Stage V	Diesel	CPCD50/60/70-XW95G	Stage V	ZF	55.4/2300	Wet brake

Note: Stage V applied for European Union also including Israel and Turkey

# Comfortable Operation



The extra foot space is provided to reduce operator fatigue significantly. The new wide-open, non-slip step makes getting in and out easy and safe.

The optional Electro-hydraulic proportional control system contributes more sensitive and precise load handling. The easy-to-operate levers provide total load handling operation. An armrest is provided to reduce fatigue.

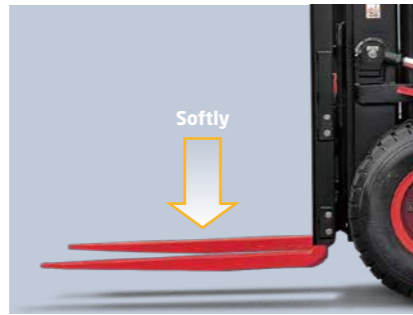

In addition to the soft landing system, the soft lifting system is adopted (front lifting cylinders of triplex mast and full free duplex mast), as a result, the noise and shock of the mast significantly decreases.

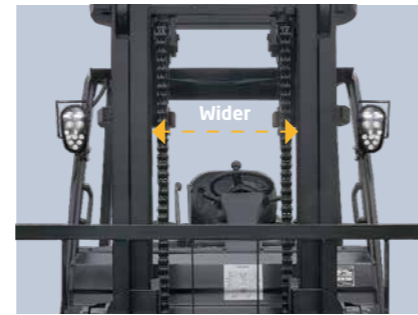

The new design mast provides broad forward visibility due to the distance between inside mast is increase 60mm.

# Productivity

Thanks to the series technological innovations, the efficiency of the truck is improved, the energy consumption is reduced.



By optimizing transmission design, the power train provides higher efficiency, and the Max. driving speed is increased **20%**



The new efficiency LED lighting system and new type reflector reduce energy consumption, improve illumination performance and prolong working life.

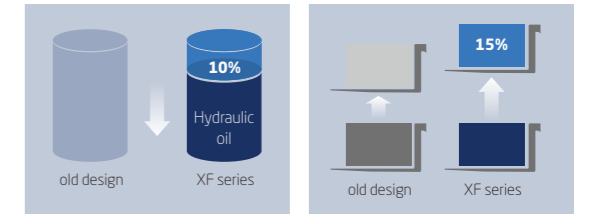

The new patent dynamic load sensing hydraulic steering system contributes to reduce loss of hydraulic, improve energy consumption and increase 15% lifting speed.

*In developing the XF 5-7t series, comfort and easy operation is always considered, for example, improved vibrating levels, compound engine damper and full floating seat and cabin are applied. Comfortable also contribute to increased productivity.*



1. The new, relocated easy-to-see LCD meter lets the operator check on all aspects of operational status at a glance.
2. The new automobile-style light/turn-signal lever and forward-reverse lever are ergonomically designed and arranged to improve comfort and productivity.
3. Only 90N parking brake force is required.
4. The small diameter steering wheel with tilt adjustment provides the ideal operating position. The superior responsiveness of the steering wheel optimizes maneuverability even in narrow spaces.
5. The automobile-style suspended pedals provide more ergonomic operation.

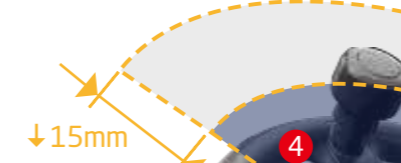

# Reliability

By focusing on enhancing reliability, reducing downtime, the XF series is able to make the greater productivity for customer.



The new stamped air cleaner featuring tangential intake, double seal with safety filter is durable, corrosion-free and vibration-resistant, provides better filter efficiency and lower intake resistance than the previous.

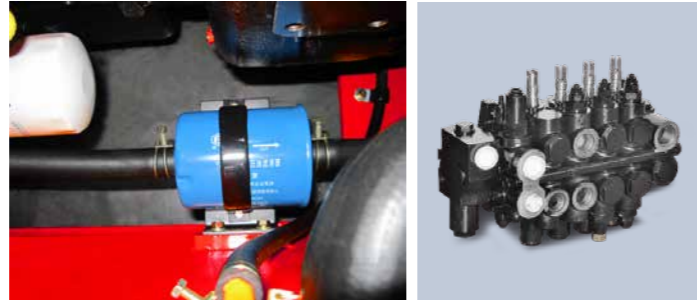

Brake oil and steering oil are separated, non-interference in each other, using dynamic load sensing steering system, more energy efficient.

The patent plated-fin type aluminum radiator is applied, the heat exchanging is approved, and improves the capability for operation in severe environments.



High strength chassis, mast and front/rear axle are to make sure the reliability of the truck, even for high strength application.

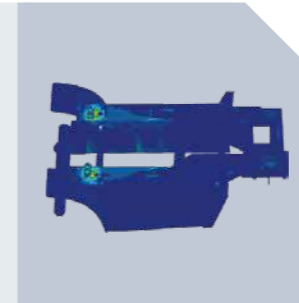

There're four levels shock absorption applied to reduced the vibration from the road to the driver. The damping pad is applied reduce the vibration. Like between the steering axle and the chassis, The engine, torque convertor and the chassis, the overhead guard and the chassis. And the suspension seat is another vibration reduction.



All the controllers, relays, and safety fuses are allocated in the controller box, free to water and dust. The main electronic components are waterproof, which is capable operator in severe environment. And the famous brand air-filter is also applied in the truck.

# Easy Maintenance



Careful design facilitates inspection and servicing. Easy maintenance reduces the amount of downtime and helps to reduce cost also.

The location of the air-filter is easy to reach, and it's very easy to replace the filter.

The rotating LPG bottle holder is easy to replace the bottle, reduces the downtime.

All the locations of the engine oil level dipstick, filter of hydraulic, water separator are easy to reach, and very easy for engineer to check.

There's gas spring support for the front cover of radiator, and it can auto-open when the rear cover of radiator is opened.

# Safety

A wide range of technologies are applied to ensure absolute safety for both the operator and those in the surrounding.



There's an energy accumulator applied in the braking system, which means when the engine is shut down, it can also provide more than 4 times emergency brake.



The locking device of the engine hood damper and parking brake help add to safety.



1. The seat sensor system incorporates lifting/tilting and traveling locking function. When the operator leaves the seat, the system automatically locks lifting/tilting and disables traveling to ensure safety.
2. A throttling device is adopted to avoid the mast being out of control even some pipes are broken.

# Standards

Transmission	Steering	Chassiss	Control	Hydraulic
<ul style="list-style-type: none"> <li>/ Suspension transmission</li> <li>/ Oil filter</li> <li>/ Dipstick</li> <li>/ Oil cooler</li> <li>/ Non-asbesttos bake</li> <li>/ Wet brake (w65/w95)</li> </ul>	<ul style="list-style-type: none"> <li>/ Full hydraulic power steering</li> <li>/ Smaller diameter steering wheel</li> <li>/ Adjuster of steering wheel</li> </ul>	<ul style="list-style-type: none"> <li>/ Skidproof pedal</li> <li>/ Rubber pedal</li> <li>/ Engine hood spring</li> </ul>	<ul style="list-style-type: none"> <li>/ Power steering</li> <li>/ Suspension pedal</li> <li>/ Integrated combination switch</li> <li>/ Parking brake</li> </ul>	<ul style="list-style-type: none"> <li>/ Dynamic load sending control valve</li> <li>/ Hydraulic oil filter</li> <li>/ Tilt cylinder self-lock valve</li> <li>/ Hydraulic oil dipstick</li> <li>/ Accumulator</li> </ul>

Truck	Power	Electronics	Mast	
<ul style="list-style-type: none"> <li>/ Traction device</li> <li>/ Hand grip</li> <li>/ Standard seat</li> <li>/ Standard overhead guard</li> <li>/ Waterproof cover on the guard</li> <li>/ Back view mirror</li> <li>/ Pneumatic tyres</li> <li>/ Toolbox</li> </ul>	<ul style="list-style-type: none"> <li>/ Big capacity aluminum radiator</li> <li>/ Whirlwind air cleaner</li> <li>/ Safety filter</li> <li>/ High-efficient intake muffler</li> <li>/ High-efficient exhaust muffler</li> <li>/ Middle-positioned exhaust system</li> <li>/ High-positioned exhaust system (w95)</li> </ul>	<ul style="list-style-type: none"> <li>/ High-efficient front lights</li> <li>/ High-efficient LED rear lights</li> <li>/ Service-free start battery</li> <li>/ Combination controller</li> <li>/ LCD display</li> <li>/ Neutual switch</li> <li>/ Hour meter</li> <li>/ Fuel gauge</li> <li>/ Water temperature gauge</li> </ul>	<ul style="list-style-type: none"> <li>/ Pre-heat indicator</li> <li>/ Charging indicator</li> <li>/ Engine fuel pressure warning</li> <li>/ Oil temperature</li> <li>/ Horn</li> <li>/ Reversing buzzer</li> <li>/ Air-filter with jam sensor</li> <li>/ Emergency power off</li> </ul>	<ul style="list-style-type: none"> <li>/ Standard wide view duplex mast</li> <li>/ Standard forks</li> <li>/ Standard fork carriage</li> <li>/ Standard load back rest</li> <li>/ Mast speed limiting valve</li> <li>/ Load safety valve</li> <li>/ Mast down buffer device</li> <li>/ Mast up buffer device</li> <li>/ Side roller</li> </ul>

# Options

Truck	Transmission	Power	Hydraulic	Electronics	Mast
<ul style="list-style-type: none"> <li>/ Cabin</li> <li>/ Cabin heater</li> <li>/ Front window</li> <li>/ Super elastic tyre</li> <li>/ Non-mark tyre(white/green)</li> <li>/ Suspension seat</li> <li>/ Extinguisher</li> <li>/ Special given color</li> <li>/ Boot for tilt cylinder</li> <li>/ Counter weight net</li> <li>/ Seat sensor system</li> </ul>	<ul style="list-style-type: none"> <li>/ Japanese drum brake</li> <li>/ Wet brake</li> </ul>	<ul style="list-style-type: none"> <li>/ Upright exhaust system</li> <li>/ Air pre-cleaner</li> <li>/ Net cover of radiator</li> <li>/ Spark arrester</li> <li>/ Purified exhaust system</li> <li>/ Fan protector</li> </ul>	<ul style="list-style-type: none"> <li>/ Auxiliary hydraulic valve</li> <li>/ Electro-hydraulic</li> <li>/ Proportional control system</li> </ul>	<ul style="list-style-type: none"> <li>/ OBD</li> <li>/ Front working light</li> <li>/ Rear working light</li> <li>/ Warning lamp</li> </ul>	<ul style="list-style-type: none"> <li>/ Duplex wide view free-lift mast</li> <li>/ Triplex wide view free-lift mast</li> <li>/ Special forks</li> <li>/ Wider fork carriage</li> <li>/ Widerload back rest</li> </ul>

# Optional Attachments

- / Paper roll clamp
- / Rotating bale clamp
- / Load stabilizer
- / Multi-drum clamp
- / Bale clamp
- / Drum clamp
- / Dumping clamp
- / Crane arm
- / String Pole
- / Sideshifter
- / Rotating forks
- / Fork extensioner
- / Load release device
- / Carton clamp
- / Push-pull device
- / Bucket
- / Hook
- / Lengthened fork

